

Border Alert System for Fishermen Using GPS System

Asif Iqbal Mulla, Sushanth K J, Prashanth Kumar H R, Abubakar Shameez

Abstract— The livelihood of fishermen is such that he crosses the country border unknowingly and poses threats to them by being killed or captured. The sea borders between countries are not easily identifiable which is the main reason behind this problem. “Border alert system for fisherman using GPS” describes about a system which helps the fishermen by notifying the country border. Global Positioning System (GPS) and Global system for mobile communication (GSM) are used for this purpose. Here GPS receiver is used to find the current location of the fishing boat. Using GPS, present latitude and longitude values are sent to microcontroller unit. Later the controller unit identifies the current location by comparing the present latitude and longitudinal values with the predefined value. After the comparison, border alert system aware the fishermen that they are about to reach the nautical border. The region is divided into normal zone and warning zone. When the boat is in normal area, the LCD displays normal zone. Thus they can make it clear that the boat is in normal area. In case if it moves further and reaches the warning zone, the LCD displays warning zone.

Index Terms— GPS, GSM, RS232.

I. INTRODUCTION

The people livelihood in coastal areas purely depends on fishing occupation in the sea. Crossing the border is being treated as a serious offence. Due to unawareness about the boundary limit, the fisherman used to cross the maritime borders. Once they cross the border, they arrested or killed by the relevant navy and they are being abducted and their boats are being captured by the neighborhood countries coastal guards. Under such situation the lives of fishermen continues to be in danger. And it has become one of the major factors for loss in humans as well as their country economic. To eliminate such difficulties a system has been developed which helps the fishermen to be aware of crossing the border line[1].

Border alert system for fisherman using GPS is one such system which protects the fishermen by notifying the country border to them by using Global Positioning System (GPS) and Global system for mobile communication (GSM). GPS receiver is used to find the current location of the fishing boat or vessel. Using GPS, the current latitude and longitude values can be determined and is then sent to the microcontroller unit. Later the controller unit finds the

current location by comparing the present latitude and longitudinal values with the predefined value. Then from the result of the comparison, this system. aware the fishermen that they are about to reach the nautical border as shown in fig 1.

II. METHODOLOGY AND OVERVIEW

In our project the following changes are implemented

- On board controlling of the whole system
- PIC microcontroller based system
- Continuous GPS location value is processed
- Since design is for real time the output is obtained instantly
- No manual operator is required
- Bluetooth and converters are not required

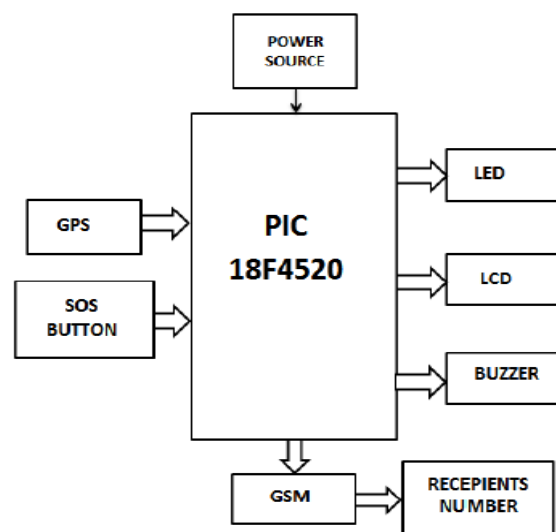

Fig 1: Border Alarm system
GPS Technology

The GPS system concept is based on time. The satellites carry very stable atomic clocks that are synchronized to each other and to ground clocks. Any drift from true time maintained on the ground is corrected daily[2]. Likewise, the satellite locations are monitored precisely. GPS receivers have clocks as well-however; they are not synchronized with true time, and are less stable. GPS satellites continuously transmit their current time and position shown in fig 2 &3. A GPS receiver monitors multiple satellites and solves equations to determine the exact position of the receiver and its deviation from true time. At a minimum, four satellites must be in view of the receiver for it to compute four unknown quantities (three position coordinates and clock deviation from satellite time).

Asif Iqbal Mulla, Sushanth K J, Prashanth Kumar H R, Abubakar Shameez, Assistant Professor, Dept, of ECE, Bearys Institute of Technology, Mangaluru, Karnataka, India

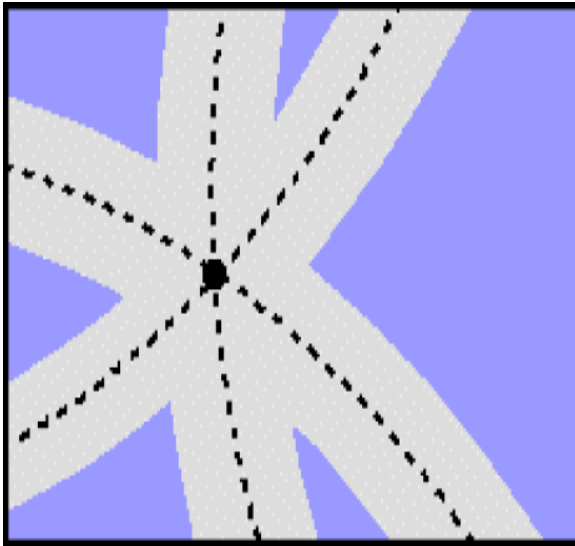

Fig.2 Calculating the Position

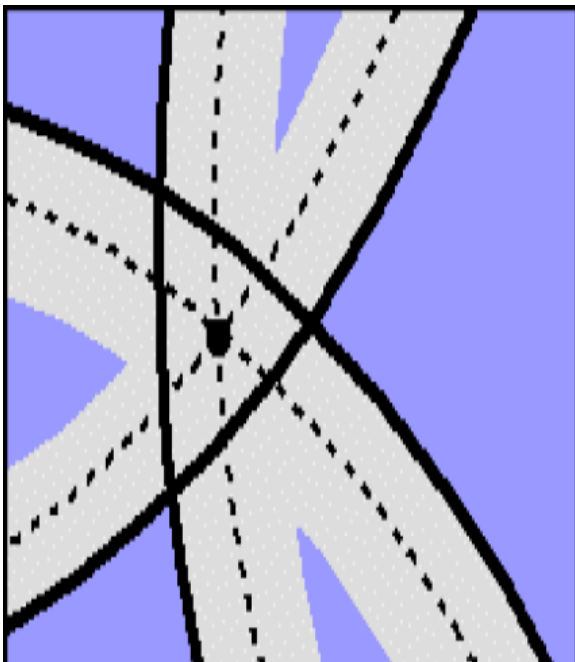

Fig. 3 Intersection Point Determination

III. IMPLEMENTATION

The various design aspects and implementation strategies are discussed under this chapter. The chapter starts with hardware implementation showing the channel diagram and after a brief explanation on various stages of implementation we move on to the software implantation. The flow chart along with the program code is given under the software implantation section shown in fig 4 & 5[3].

After finishing up with the block diagram, we then focused on building up the entire block from discrete components. Each block had some components in it to build up. Our next task was to gather information about the discrete components.

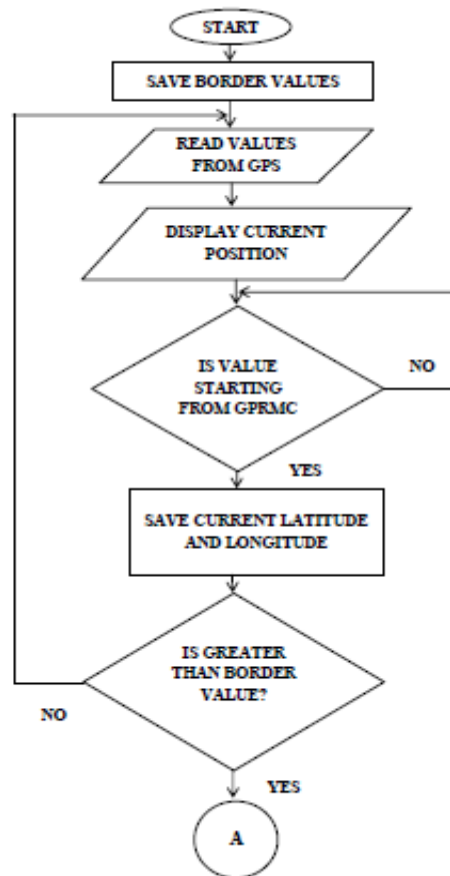

Fig.4 Initalization

Component Information Gathering

After finishing up with the block diagram, we then focused on building up the entire block from discrete components. Each block had some components in it to build up. Our next task was to gather information about the discrete components[5].

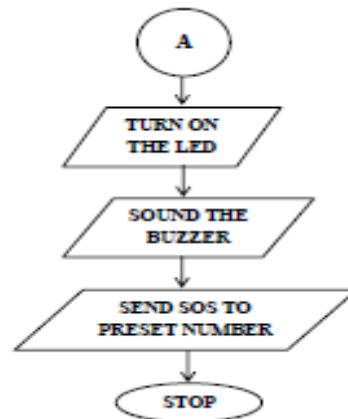

Fig.5 Execution

Individual module testing

As soon as we are done with our component information gathering, we then moved onto of the vital portion of the implementation area i.e. individual module testing. This was the first step towards hardware implementation. Each module was tested to whether they are giving the desired results. The errors were analyzed and studied before attempting it, and were corrected accordingly.

Layout Preparation

The next step after the testing was the layout preparation. After the testing, we made a layout. The interfaces between various modules were discussed and decided. All the connections between the modules were discussed and tested before assembling it to a final one. The expected output was compared with the entire layout made possible and a final layout was decided.

Module Assembling

After the layout is completed, the various modules must be assembled. This was done with the help of studying the architecture of the various modules. Connection of the modules was studied properly and tested before assembling. The output is checked to whether it is as expected[6].

Cold Test

It is nothing but when the system is in off state, the connection between the various components is verified using a multi-meter. This process is called as cold test.

Hot Test

Hot test stands for the test performed on the system for its proper functionality when it is in ON state.

Coding

It is a process involving design, writing, testing, debugging & maintaining source code of computer programs. This source code is written in one or more programming languages. Purpose is to create a set of instructions that computers use to perform specific operations or to exhibit desired behaviors.

IV. EXPERIMENTAL RESULTS

Border alert system for fishermen is used to detect the boundary location and warn the fishermen in danger situations. It not only finds the GPS value, but also compares with the stored value in the microcontroller, and makes a decision as to whether the fishermen is in the warning range or not.

Fig 6 shows the overall components and complete setup of working module

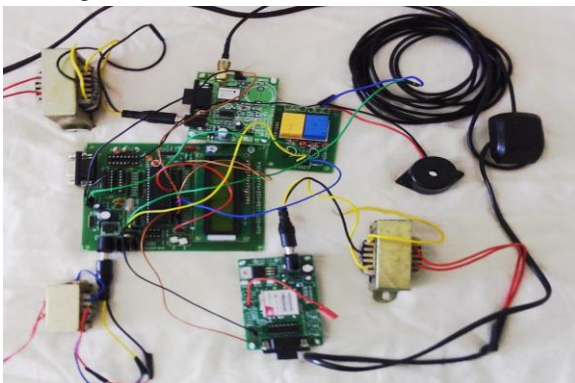

Fig : 6 Complete setup of working module

The LCD displays the initialization message when the module is powered up. The message to be displayed can be programmed as shown in the fig 7.



Fig:7 Display initialization

After the initialization the GPS values of current position will be displayed in the LCD. The calibration of GPS module takes some delay to display the actual boundary values as shown in Fig 8 & 9. Until then a default value will be displayed in LCD. After the calibration the actual latitude and longitude values are displayed in the LCD.



Fig : 8 Display of boundary values (before calibration)

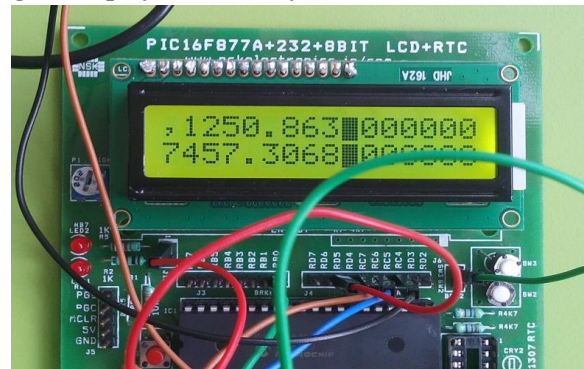

Fig : 9 Display of boundary values (after calibration)

If the current location value is found to be greater than the stored value in the microcontroller, the fishermen are warned with the help of series of events. The first event is an alert message that will be displayed in the LCD, followed by buzzer sound. Finally an SOS message will be sent to the preset number showing warning as shown in Fig 10 & 11.



Fig: 10 Alert Message Displayed In LCD



Fig: 11 Sending Message to Preset Number

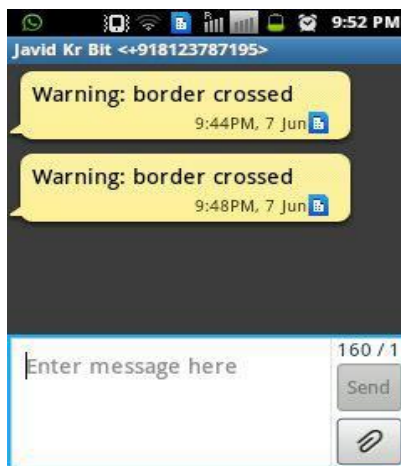

Fig. 12 Received message

which causes loss to its life. Through this project a GPS based security system is provided to the fisherman so that they can find out when they are in danger.

Thus the fishermen can easily identify the national sea borders and therefore prevents them from entering their area. Thus saving their lives and providing good relationship with the neighboring countries. This system is an implication of security system for safe navigation of mariner's auto boat. It is a helpful step in saving lives of fisherman and a useful contribution to the society.

REFERENCES

- [1] K. Suresh Kumar et. al. / Design of low cost maritime boundary identification device using gps system/International Journal of Engineering Science and Technology Vol. 2(9), 2010, 4665-4672.
- [2] M Sivaramaganesha/International journal of innovative research in electrical, electronics, instrumentation and control engineering vol. 2, issue 3, march 2014
- [3]http://www.thehindu.com/multimedia/dynamic/01689/TH_09_GROWING_rev__1689954g
- [4] S. Mani Sunder/Deep sea fishermen patrol system for coastal intruder positioning/ Scientific Engineering and Technology (ISSN : 1581)Volume 2 Issue 3, PP : 129
- [5]GoogleMAPS API<http://code.google.com/apis/maps>
- [6] P.Satheesh, Maritime Border Refuge System [MBR]/ National Conference on Emerging Trends in Computer, Communication & Instrumentation in Strengthen Security.

V. CONCLUSION

The "Border Alert System for Fishermen Using GPS System" is a system that implements GPS and Embedded system together to create a security system for fishermen boats. The fisherman, while navigating crosses the maritime boundary, unknowingly as they are unable to visualize it in the ocean